



# 2018 IRC Deck Construction

## WHEN ARE DECKS REQUIRED TO BE PERMITTED ?

- *DECKS OVER 200 SQ. FT*
- *DECKS OVER 30" FROM GRADE*
- *DECKS THAT ARE COVERED*



# Materials



- ▶ Must be No. 2 Grade lumber or greater.
- ▶ Be pressure treated or naturally durable wood to resist rot & decay.
- ▶ Wood must be termite resistant.
- ▶ All pressure treated wood in contact with the ground must be labeled for such usage.
- ▶ Plastic composite material must be Decay & Termite resistant and installed to manufacturer specifications on allowable load and maximum allowable span.



# Fasteners

- Fasteners, including nuts and washers, for Pressure treated wood shall be of hot-dipped, zinc-coated galvanized steel, stainless steel, silicon bronze or copper.
  - Coating types and weights for connectors in contact with pressure treated wood shall be in accordance with the connector manufacturer's recommendations.
- 



# Flashing

- Flashing must have a nominal thickness not less than 0.019 inch or be of an approved material that is compatible with the substrate of the structure and the decking materials.
- 

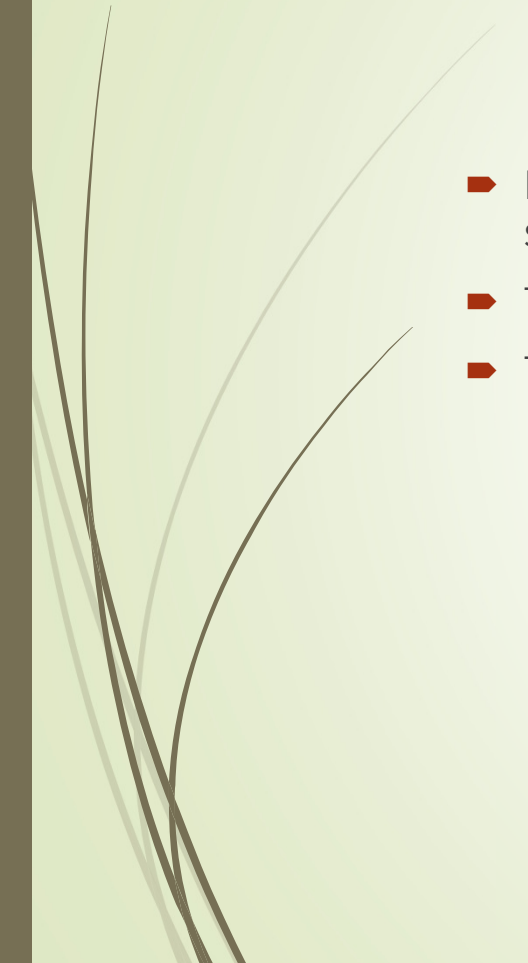

# Footings

- Decks shall be supported on concrete footings or other approved structural systems designed to accommodate all loads.
  - The depth of the footing must be 12 inches below undisturbed soil.
  - The minimum size of footings shall be in accordance with table R507.3.1.
- 

**TABLE R507.3.1  
MINIMUM FOOTING SIZE FOR DECKS**

LIVE OR GROUND SNOW LOAD <sup>b</sup> (psf)	TRIBUTARY AREA (sq. ft.)	LOAD BEARING VALUE OF SOILS <sup>a,c,d</sup> (psf)											
		1500 <sup>e</sup>			2000 <sup>e</sup>			2500 <sup>e</sup>			≥ 3000 <sup>e</sup>		
		Side of a square footing (inches)	Diameter of a round footing (inches)	Thickness (inches)	Side of a square footing (inches)	Diameter of a round footing (inches)	Thickness (inches)	Side of a square footing (inches)	Diameter of a round footing (inches)	Thickness (inches)	Side of a square footing (inches)	Diameter of a round footing (inches)	Thickness (inches)
40	20	12	14	6	12	14	6	12	14	6	12	14	6
	40	14	16	6	12	14	6	12	14	6	12	14	6
	60	17	19	6	15	17	6	13	15	6	12	14	6
	80	20	22	7	17	19	6	15	17	6	14	16	6
	100	22	25	8	19	21	6	17	19	6	15	17	6
	120	24	27	9	21	23	7	19	21	6	17	19	6
	140	26	29	10	22	25	8	20	23	7	18	21	6
160	28	31	11	24	27	9	21	24	8	20	22	7	
50	20	12	14	6	12	14	6	12	14	6	12	14	6
	40	15	17	6	13	15	6	12	14	6	12	14	6
	60	19	21	6	16	18	6	14	16	6	13	15	6
	80	21	24	8	19	21	6	17	19	6	15	17	6
	100	24	27	9	21	23	7	19	21	6	17	19	6
	120	26	30	10	23	26	8	20	23	7	19	21	6
	140	28	32	11	25	28	9	22	25	8	20	23	7
160	30	34	12	26	30	10	24	27	9	21	24	8	
60	20	12	14	6	12	14	6	12	14	6	12	14	6
	40	16	19	6	14	16	6	13	14	6	12	14	6
	60	20	23	7	17	20	6	16	18	6	14	16	6
	80	23	26	9	20	23	7	18	20	6	16	19	6
	100	26	29	10	22	25	8	20	23	7	18	21	6
	120	28	32	11	25	28	9	22	25	8	20	23	7
	140	31	35	12	27	30	10	24	27	9	22	24	8
160	33	37	13	28	32	11	25	29	10	23	26	9	
70	20	12	14	6	12	14	6	12	14	6	12	14	6
	40	18	20	6	15	17	6	14	15	6	12	14	6
	60	21	24	8	19	21	6	17	19	6	15	17	6
	80	25	28	9	21	24	8	19	22	7	18	20	6
	100	28	31	11	24	27	9	21	24	8	20	22	7
	120	30	34	12	26	30	10	24	27	9	21	24	8
	140	33	37	13	28	32	11	25	29	10	23	26	9
160	35	40	15	30	34	12	27	31	11	25	28	9	

For SI: 1 inch = 25.4 mm, 1 square foot = 0.0929 m<sup>2</sup>, 1 pound per square foot = 0.0479 kPa.

- a. Interpolation permitted, extrapolation not permitted.
- b. Based on highest load case: Dead + Live or Dead + Snow.
- c. Assumes minimum square footing to be 12 inches x 12 inches x 6 inches for 6 x 6 post.
- d. If the support is a brick or CMU pier, the footing shall have a minimum 2-inch projection on all sides.
- e. Area, in square feet, of deck surface supported by post and footings.



# Deck Post to Footing Connection

- Where posts bear on concrete footings, lateral restraint shall be provided by manufactured connectors or a minimum post embedment of 12 inches in surrounding soils or concrete piers.
- 

IN  
E SOILS

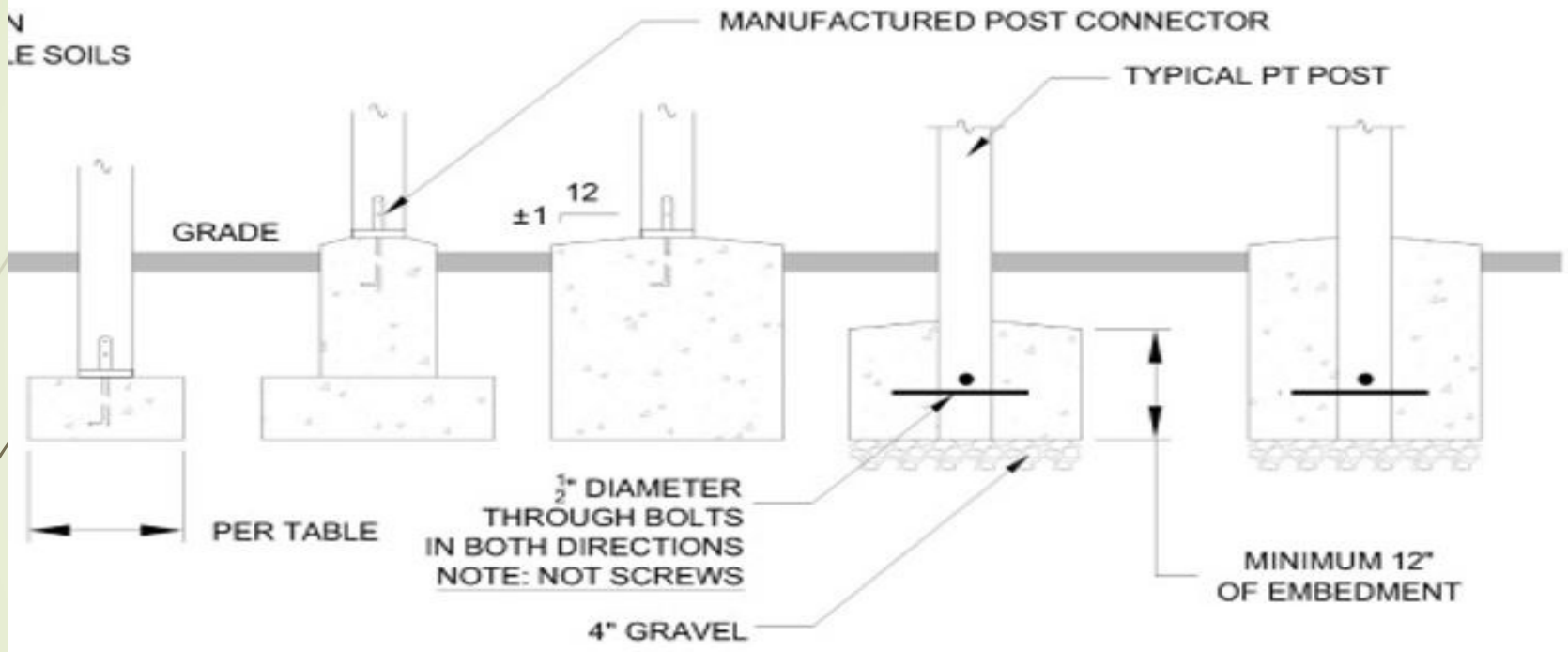

NOTE:  
POSTS MUST BE CENTERED ON OR IN FOOTING



# Deck Post Height

- For single-level wood-framed decks, posts shall be sized in accordance with Table R507.4.
- 

**TABLE R507.4  
DECK POST HEIGHT<sup>a</sup>**

DECK POST SIZE	MAXIMUM HEIGHT <sup>a, b</sup> (feet-inches)
4 × 4	6-9 <sup>c</sup>
4 × 6	8
6 × 6	14
8 × 8	14

For SI: 1 inch = 25.4 mm, 1 foot = 304.8 mm,  
1 pound per square foot = 0.0479 kPa.

- a. Measured to the underside of the beam.
- b. Based on 40 psf live load.
- c. The maximum permitted height is 8 feet for one-ply and two-ply beams. The maximum permitted height for three-ply beams on post cap is 6 feet 9 inches.

# Deck Beams

- Maximum allowable spans for wood deck beams, as shown in Figure R507.5, shall be in accordance with Table R507.5. Beam plies shall be fastened with two rows of 10d (3-inch X 0.128-inch) nails minimum at 16 inches (406mm) on center along each edge. Beams shall be permitted to cantilever at each end up to one-fourth of the allowable beam span. Deck beams of other materials shall be permitted where designed in accordance with accepted engineering practices.

**TABLE R507.5**  
**DECK BEAM SPAN LENGTHS<sup>a, b, g</sup> (feet - inches)**

SPECIES <sup>e</sup>	SIZE <sup>d</sup>	DECK JOIST SPAN LESS THAN OR EQUAL TO: (feet)						
		6	8	10	12	14	16	18
Southern pine	1 - 2 × 6	4-11	4-0	3-7	3-3	3-0	2-10	2-8
	1 - 2 × 8	5-11	5-1	4-7	4-2	2-10	3-7	3-5
	1 - 2 × 10	7-0	6-0	5-5	4-11	4-7	4-3	4-0
	1 - 2 × 12	8-3	7-1	6-4	5-10	5-5	5-0	4-9
	2 - 2 × 6	6-11	5-11	5-4	4-10	4-6	4-3	4-0
	2 - 2 × 8	8-9	7-7	6-9	6-2	5-9	5-4	5-0
	2 - 2 × 10	10-4	9-0	8-0	7-4	6-9	6-4	6-0
	2 - 2 × 12	12-2	10-7	9-5	8-7	8-0	7-6	7-0
	3 - 2 × 6	8-2	7-5	6-8	6-1	5-8	5-3	5-0
	3 - 2 × 8	10-10	9-6	8-6	7-9	7-2	6-8	6-4
	3 - 2 × 10	13-0	11-3	10-0	9-2	8-6	7-11	7-6
3 - 2 × 12	15-3	13-3	11-10	10-9	10-0	9-4	8-10	
Douglas fir-larch <sup>e</sup> , hem-fir <sup>e</sup> , spruce-pine-fir <sup>e</sup> , redwood, western cedars, ponderosa pine <sup>e</sup> , red pine <sup>f</sup>	3 × 6 or 2 - 2 × 6	5-5	4-8	4-2	3-10	3-6	3-1	2-9
	3 × 8 or 2 - 2 × 8	6-10	5-11	5-4	4-10	4-6	4-1	3-8
	3 × 10 or 2 - 2 × 10	8-4	7-3	6-6	5-11	5-6	5-1	4-8
	3 × 12 or 2 - 2 × 12	9-8	8-5	7-6	6-10	6-4	5-11	5-7
	4 × 6	6-5	5-6	4-11	4-6	4-2	3-11	3-8
	4 × 8	8-5	7-3	6-6	5-11	5-6	5-2	4-10
	4 × 10	9-11	8-7	7-8	7-0	6-6	6-1	5-8
	4 × 12	11-5	9-11	8-10	8-1	7-6	7-0	6-7
	3 - 2 × 6	7-4	6-8	6-0	5-6	5-1	4-9	4-6
	3 - 2 × 8	9-8	8-6	7-7	6-11	6-5	6-0	5-8
	3 - 2 × 10	12-0	10-5	9-4	8-6	7-10	7-4	6-11
3 - 2 × 12	13-11	12-1	10-9	9-10	9-1	8-6	8-1	

For SI: 1 inch = 25.4 mm, 1 foot = 304.8 mm, 1 pound per square foot = 0.0479 kPa, 1 pound = 0.454 kg.

a. Ground snow load, live load = 40 psf, dead load = 10 psf, L/Δ = 360 at main span, L/Δ = 180 at cantilever with a 220-pound point load applied at the end.

b. Beams supporting deck joists from one side only.

c. No. 2 grade, wet service factor.

d. Beam depth shall be greater than or equal to depth of joists with a flush beam condition.

e. Includes incising factor.

f. Northern species. Incising factor not included.

g. Beam cantilevers are limited to the adjacent beam's span divided by 4

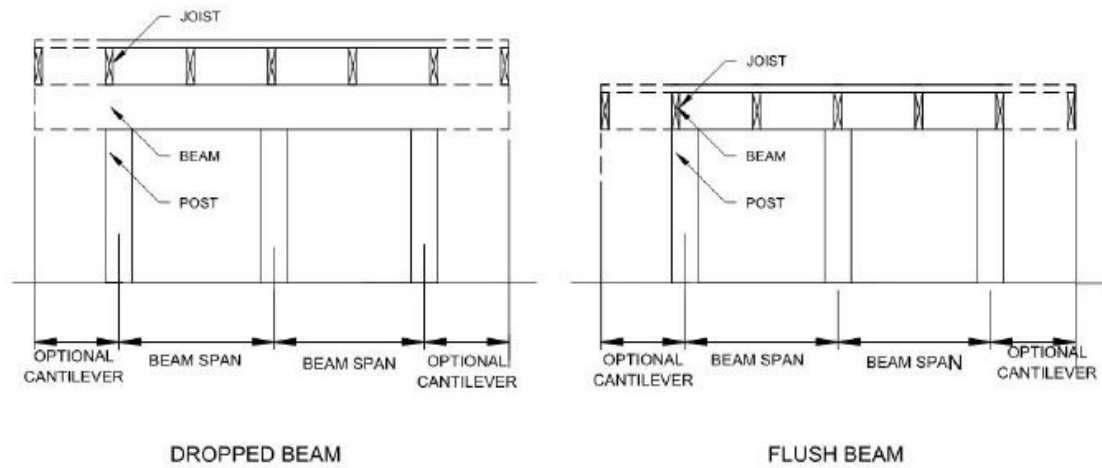

**FIGURE R507.5  
TYPICAL DECK JOIST SPANS**

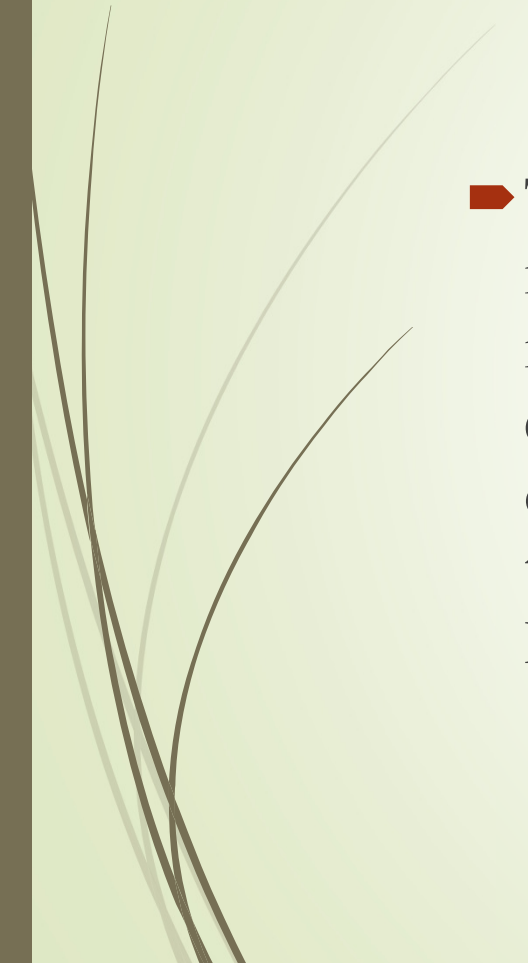

## Deck Beam Bearing

- ▶ The ends of beams shall have not less than 1.5 inches (38 mm) of bearing on wood or metal and not less than 3 inches (76 mm) of bearing on concrete or masonry for the entire width of the beam. Where multiple span beams bear on intermediate posts, each ply must have full bearing on the post in accordance with Figures R507.5.1(1) and R507.5.1(2).
- 



## Deck Beam Connection to Supports

- ▶ Deck beams shall be attached to supports in a manner capable of transferring vertical loads and resisting horizontal displacement. Deck beam connections to wood posts shall be in accordance with Figures R507.5.1(1) and R507.5.1(2). Manufactured post-to-beam connectors shall be sized for the post and beam sizes. Bolts shall have washers under the head and nut.
- 

FIGURE R507.5.1(1)  
DECK BEAM TO DECK POST



For SI: 1 inch = 25.4 mm.

FIGURE R507.5.1(2)  
NOTCHED POST-TO-BEAM CONNECTION

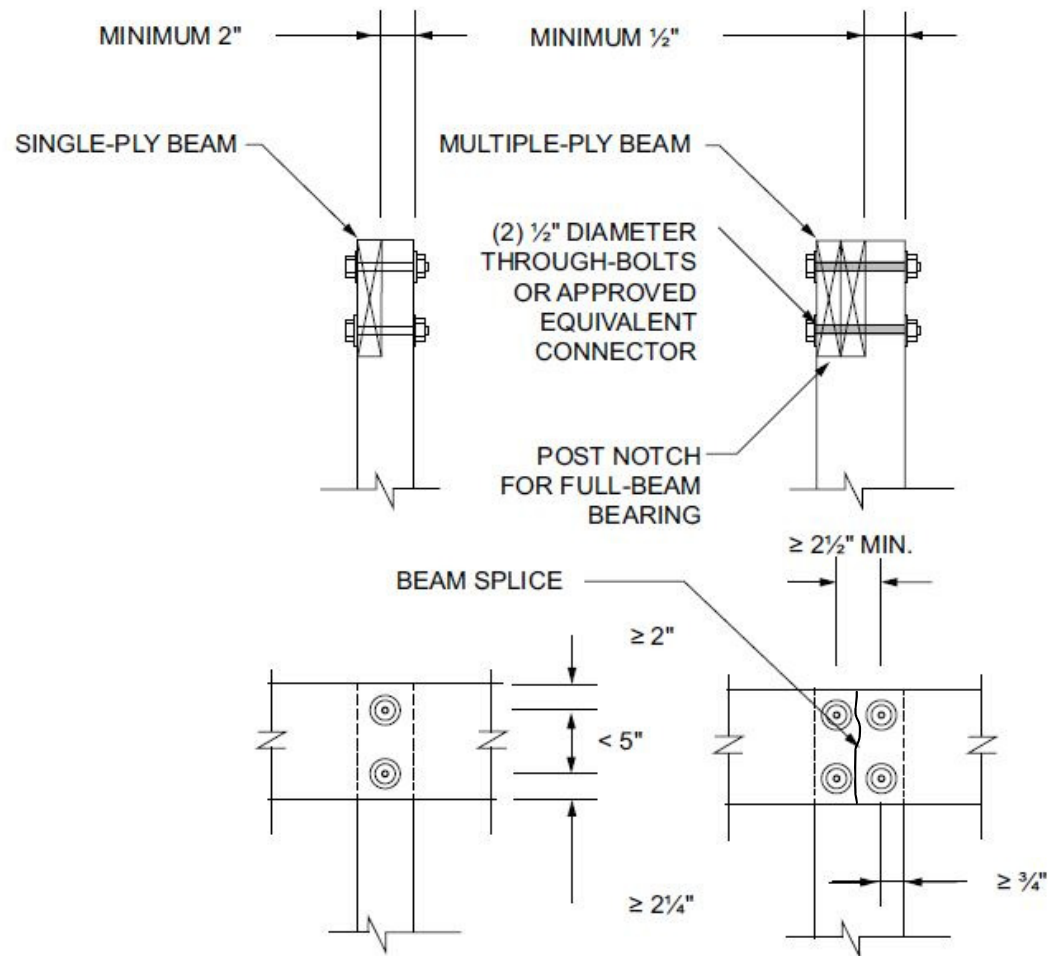
BEAM SPLICE  
(IF REQUIRED)  
MUST OCCUR  
OVER POST

APPROVED  
POST CAP

BEAM OVER POST CAP

5½" MINIMUM FOR  
BEAM SPLICES  
(IF REQUIRED)

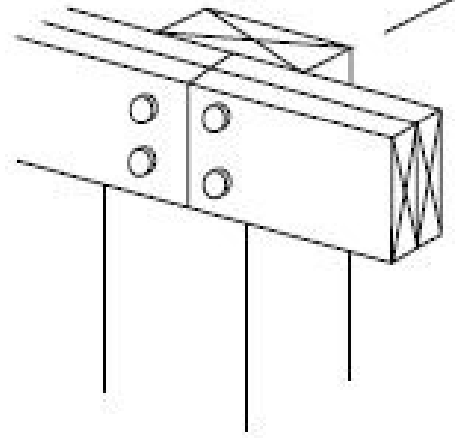

BEAM OVER POST

# Deck Joist

- ▶ Maximum allowable spans for wood deck joists, as shown in Figure R507.6, shall be in accordance with Table R507.6. The maximum joist spacing shall be limited by the decking materials in accordance with Table R507.7. The maximum joist cantilever shall be limited to one-fourth of the joist span or the maximum cantilever length specified in Table R507.6, whichever is less.
- ▶ The table lists the maximum span length as well as the maximum allowable cantilever length. Cantilever lengths are controlled by either one-fourth of the actual span length (measured from center of support to center of support) or the table value for cantilever length, whichever is smaller.

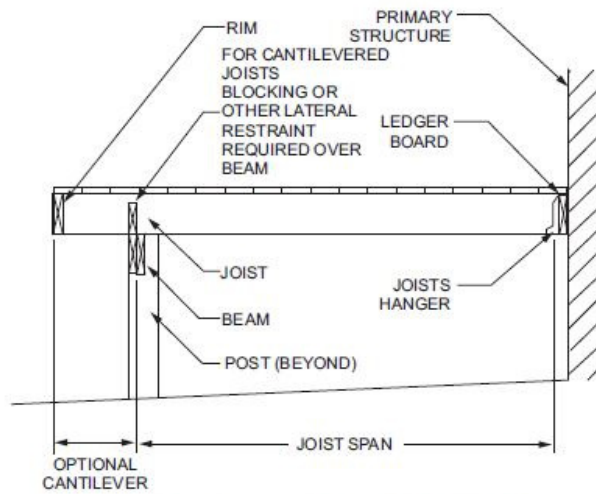

CANTILEVERED JOISTS WITH DROPPED BEAM

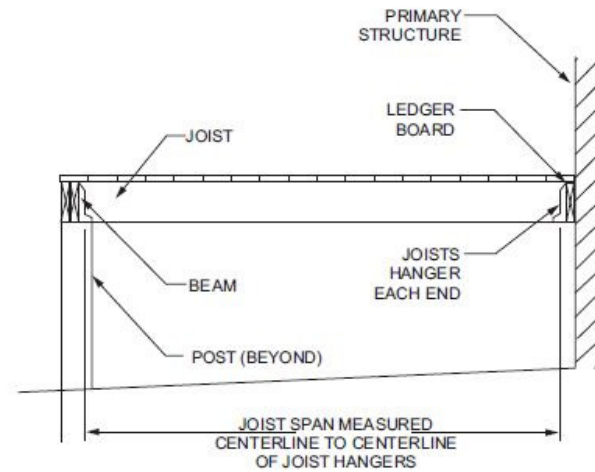

JOISTS WITH FLUSH BEAM

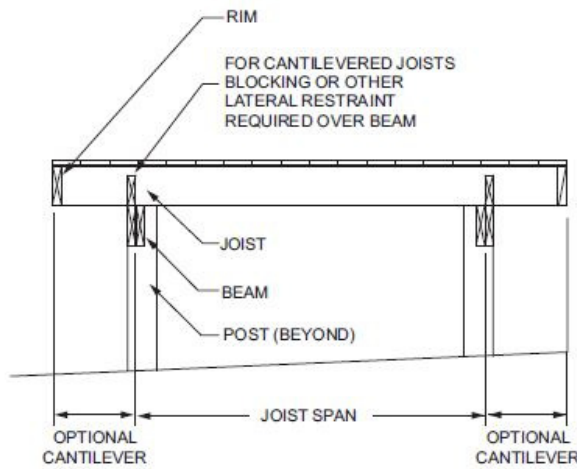

JOISTS ON FREE-STANDING DECK WITH DROPPED BEAM

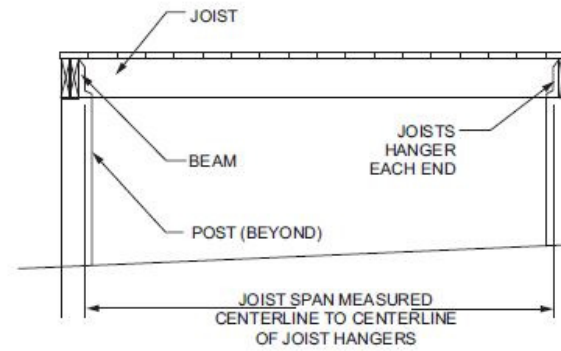

JOISTS ON FREE-STANDING DECK WITH FLUSH BEAM

FIGURE R507.6  
TYPICAL DECK JOIST SPANS

**TABLE R507.6  
DECK JOIST SPANS FOR COMMON LUMBER SPECIES (ft. - in.)**

SPECIES <sup>a</sup>	SIZE	ALLOWABLE JOIST SPAN <sup>b</sup>			MAXIMUM CANTILEVER <sup>c, f</sup>		
		SPACING OF DECK JOISTS (inches)			SPACING OF DECK JOISTS WITH CANTILEVERS <sup>e</sup> (inches)		
		12	16	24	12	16	24
Southern pine	2 × 6	9-11	9-0	7-7	1-3	1-4	1-6
	2 × 8	13-1	11-10	9-8	2-1	2-3	2-5
	2 × 10	16-2	14-0	11-5	3-4	3-6	2-10
	2 × 12	18-0	16-6	13-6	4-6	4-2	3-4
Douglas fir-larch <sup>d</sup> , hem-fir <sup>d</sup> , spruce-pine-fir <sup>d</sup> ,	2 × 6	9-6	8-8	7-2	1-2	1-3	1-5
	2 × 8	12-6	11-1	9-1	1-11	2-1	2-3
	2 × 10	15-8	13-7	11-1	3-1	3-5	2-9
	2 × 12	18-0	15-9	12-10	4-6	3-11	3-3
Redwood, western cedars, ponderosa pine <sup>e</sup> , red pine <sup>e</sup>	2 × 6	8-10	8-0	7-0	1-0	1-1	1-2
	2 × 8	11-8	10-7	8-8	1-8	1-10	2-0
	2 × 10	14-11	13-0	10-7	2-8	2-10	2-8
	2 × 12	17-5	15-1	12-4	3-10	3-9	3-1

For SI: 1 inch = 25.4 mm, 1 foot = 304.8 mm, 1 pound per square foot = 0.0479 kPa, 1 pound = 0.454 kg.

- a. No. 2 grade with wet service factor.
- b. Ground snow load, live load = 40 psf, dead load = 10 psf, L/Δ = 360.
- c. Ground snow load, live load = 40 psf, dead load = 10 psf, L/Δ = 360 at main span, L/Δ = 180 at cantilever with a 220-pound point load applied to end.
- d. Includes incising factor.
- e. Northern species with no incising factor.
- f. Cantilevered spans not exceeding the nominal depth of the joist are permitted.



## Deck Joist Bearing

- ▶ The ends of joists shall have not less than 1.5 inches (38 mm) of bearing on wood or metal and not less than 3 inches (76 mm) of bearing on concrete or masonry over its entire width. Joists bearing on top of a multiple-ply beam or ledger shall be fastened in accordance with Table R602.3(1). Joists bearing on top of a single-ply beam or ledger shall be attached by a mechanical connector. Joist framing into the side of a beam or ledger board shall be supported by approved joist hangers.
- ▶ \*No more ledger strips, must use joist hangers.

FLOOR

21	Joist to sill, top plate or girder	4-8d box (2½" × 0.113"); or 3-8d common (2½" × 0.131"); or 3-10d box (3" × 0.128"); or 3-3" × 0.131" nails	Toe nail
----	------------------------------------	---	----------

If joist rest on a single beam





## Deck Joist Lateral Restraint

- ▶ Joist ends and bearing locations shall be provided with lateral resistance to prevent rotation. Where lateral restraint is provided by joist hangers or blocking between joists, their depth shall equal not less than 60 percent of the joist depth. Where lateral restraint is provided by rim joists, they shall be secured to the end of each joist with not fewer than three 10d (3-inch by 0.128-inch) (76 mm by 3.3 mm) nails or three No. 10x 3-inch (76 mm) long wood screws.



# Decking

- ▶ Maximum allowable spacing for joists supporting decking shall be in accordance with Table R507.7. Wood decking shall be attached to each supporting member with not less than two 8d threaded nails or two No. 8 wood screws. Other approved decking or fastener systems shall be installed in accordance with the manufacturer's installation requirements.
- 

**TABLE R507.7  
MAXIMUM JOIST SPACING FOR DECKING**

DECKING MATERIAL TYPE AND NOMINAL SIZE	MAXIMUM ON-CENTER JOIST SPACING	
	Decking perpendicular to joist	Decking diagonal to joist <sup>a</sup>
1 <sup>1</sup> / <sub>4</sub> -inch-thick wood	16 inches	12 inches
2-inch-thick wood	24 inches	16 inches
Plastic composite	In accordance with Section R507.2	In accordance with Section R507.2

For SI: 1 inch = 25.4 mm, 1 foot = 304.8 mm, 1 degree = 0.01745 rad.

a. Maximum angle of 45 degrees from perpendicular for wood deck boards.



## Vertical and Lateral Supports

- ▶ Where supported by attachment to an exterior wall, decks shall be positively anchored to the primary structure and designed for both vertical and lateral loads. Such attachment shall not be accomplished by the use of toenails or nails subject to withdrawal. For decks with cantilevered framing members, connection to exterior walls or other framing members shall be designed and constructed to resist uplift resulting from the full live load specified in Table R301.5 acting on the cantilevered portion of the deck. Where positive connection to the primary building structure cannot be verified during inspection, decks shall be self-supporting.
- 



# Ledger Details

- Deck ledgers shall be a minimum 2-inch by 8-inch (51 mm by 203 mm) nominal, pressure-preservative-treated Southern pine, incised pressure-preservative-treated hem-fir, or approved, naturally durable, No. 2 grade or better lumber. Deck ledgers shall not support concentrated loads from beams or girders. Deck ledgers shall not be supported on stone or masonry veneer.
- 



## Band Joist Details

- ▶ Band joists supporting a ledger shall be a minimum 2-inch-nominal (51 mm), solidsawn, spruce-pine-fir or better lumber or a minimum 1-inch by 9 $\frac{1}{2}$ -inch (25 mm × 241 mm) dimensional, Douglas fir or better, laminated veneer lumber. Band joists shall bear the primary structure capable of supporting all required loads.
- ▶ \*Minimum 1 1/8 inch engineered rimboard is permitted.
- ▶ \*When using floor system that does not require rim board you must block between the joist or make sure ledger bolts screw into the floor joist when deck ledger is connected.



## Ledger to Band Joist Details

- ▶ Fasteners used in deck ledger connections in accordance with Table R507.9.1.3(1) shall be hot-dipped galvanized or stainless steel and shall be installed in accordance with Table R507.9.1.3(2) and Figures R507.9.1.3(1) and R507.9.1.3(2).
- ▶ \*Cannot be fastened to brick or stone veneer.

**TABLE R507.9.1.3(1)**  
**DECK LEDGER CONNECTION TO BAND JOIST<sup>a, b</sup>**  
 (Deck live load = 40 psf, deck dead load = 10 psf, snow load ≤ 40 psf)

CONNECTION DETAILS	JOIST SPAN						
	6' and less	6'1" to 8'	8'1" to 10'	10'1" to 12'	12'1" to 14'	14'1" to 16'	16'1" to 18'
	On-center spacing of fasteners						
1/2-inch diameter lag screw with 1/2-inch maximum sheathing <sup>c, d</sup>	30	23	18	15	13	11	10
1/2-inch diameter bolt with 1/2-inch maximum sheathing <sup>d</sup>	36	36	34	29	24	21	19
1/2-inch diameter bolt with 1-inch maximum sheathing <sup>e</sup>	36	36	29	24	21	18	16

For SI: 1 inch = 25.4 mm, 1 foot = 304.8 mm, 1 pound per square foot = 0.0479 kPa.

- a. Ledgers shall be flashed in accordance with Section R703.4 to prevent water from contacting the house band joist.
- b. Snow load shall not be assumed to act concurrently with live load.
- c. The tip of the lag screw shall fully extend beyond the inside face of the band joist.
- d. Sheathing shall be wood structural panel or solid sawn lumber.
- e. Sheathing shall be permitted to be wood structural panel, gypsum board, fiberboard, lumber or foam sheathing. Up to 1/2-inch thickness of stacked washers shall be permitted to substitute for up to 1/2 inch of allowable sheathing thickness where combined with wood structural panel or lumber sheathing.

**TABLE R507.9.1.3(2)**  
**PLACEMENT OF LAG SCREWS AND BOLTS IN DECK LEDGERS AND BAND JOISTS**

MINIMUM END AND EDGE DISTANCES AND SPACING BETWEEN ROWS				
	TOP EDGE	BOTTOM EDGE	ENDS	ROW SPACING
Ledger <sup>a</sup>	2 inches <sup>d</sup>	$\frac{3}{4}$ inch	2 inches <sup>b</sup>	$1\frac{5}{8}$ inches <sup>b</sup>
Band Joist <sup>c</sup>	$\frac{3}{4}$ inch	2 inches	2 inches <sup>b</sup>	$1\frac{5}{8}$ inches <sup>b</sup>

For SI: 1 inch = 25.4 mm.

- a. Lag screws or bolts shall be staggered from the top to the bottom along the horizontal run of the deck ledger in accordance with Figure R507.9.1.3(1).
- b. Maximum 5 inches.
- c. For engineered rim joists, the manufacturer's recommendations shall govern.
- d. The minimum distance from bottom row of lag screws or bolts to the top edge of the ledger shall be in accordance with **Figure R507.9.1.3(1)**.

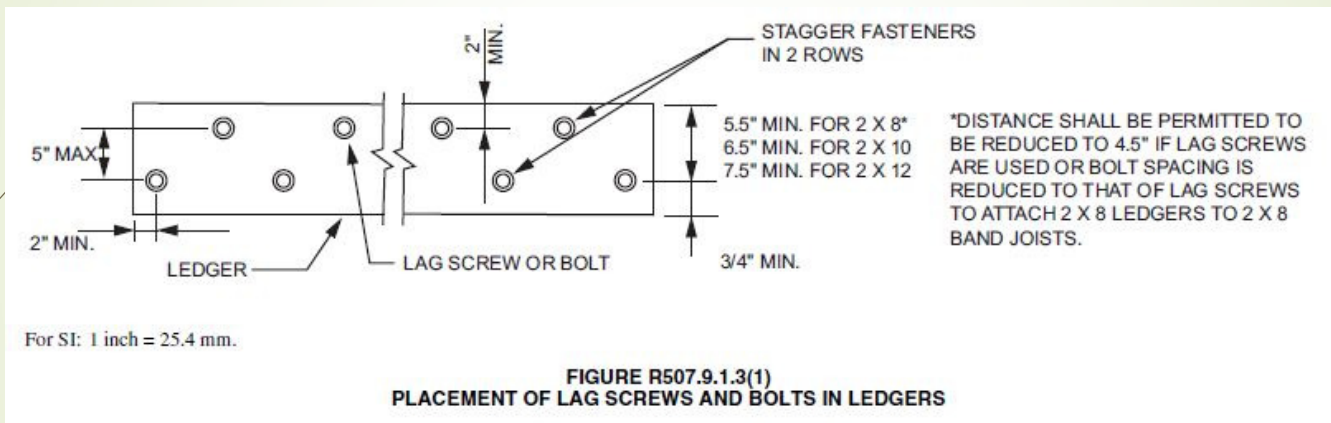



# Lateral Connection

- Lateral loads shall be transferred to the ground or to a structure capable of transmitting them to the ground. Where the lateral load connection is provided in accordance with Figure R507.9.2(1), hold-down tension devices shall be installed in not less than two locations per deck, within 24 inches (610 mm) of each end of the deck. Each device shall have an allowable stress design capacity of not less than 1,500 pounds (6672 N). Where the lateral load connections are provided in accordance with Figure R507.9.2(2), the hold-down tension devices shall be installed in not less than four locations per deck, and each device shall have an allowable stress design capacity of not less than 750 pounds (3336 N).
- 

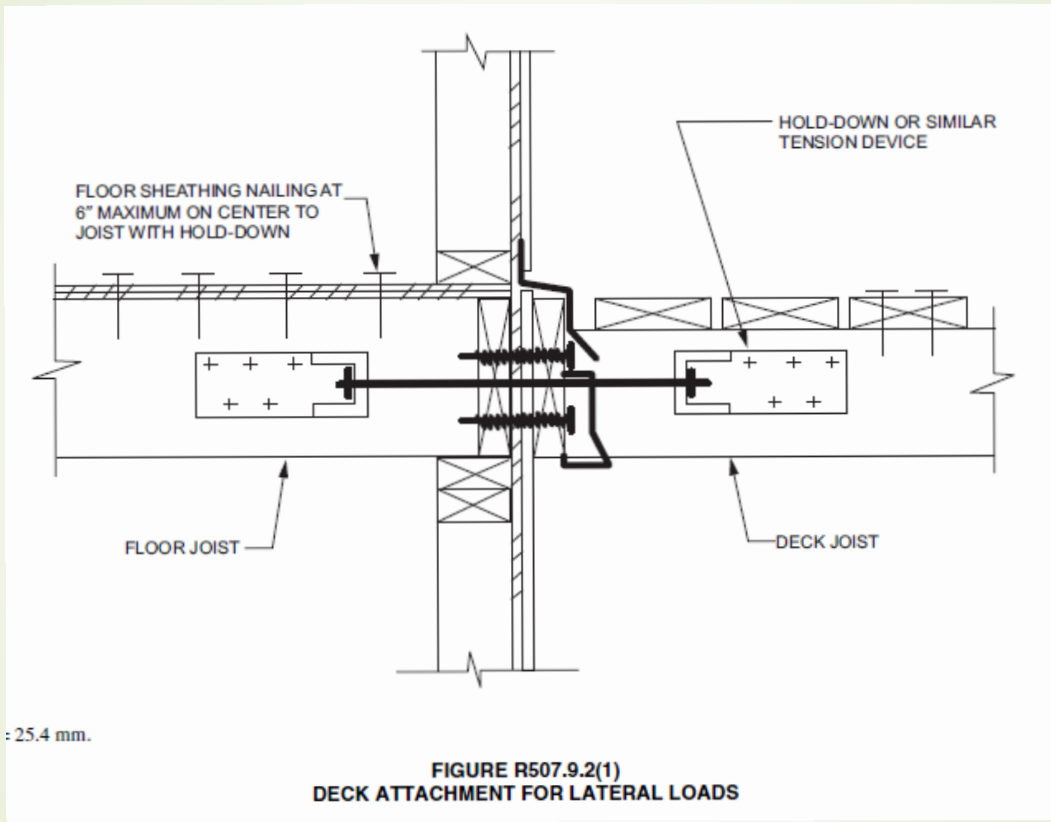

**NOTE:**  
THIS DETAIL IS APPLICABLE  
WHERE FLOOR JOISTS ARE  
PARALLEL TO DECK JOISTS.

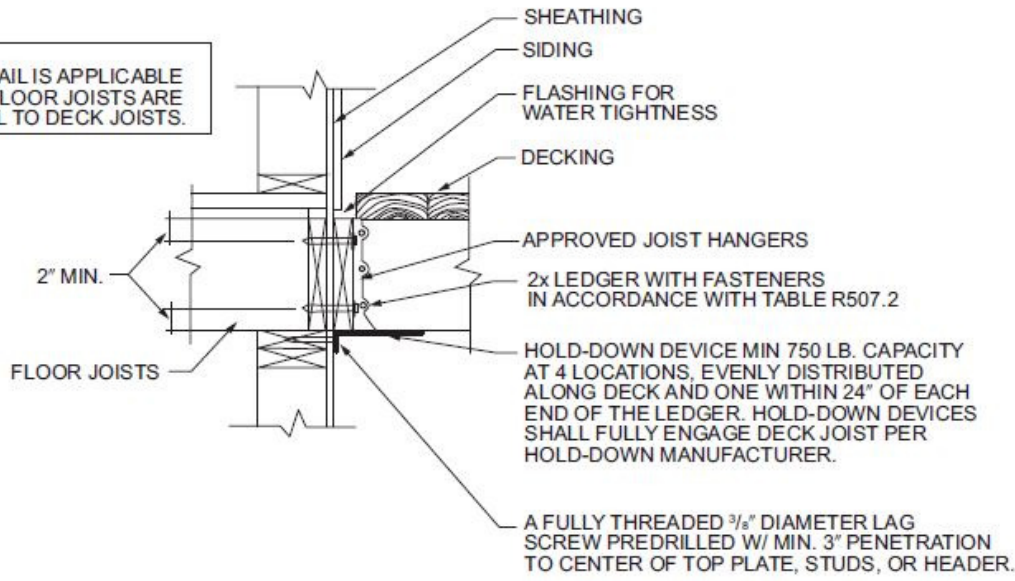

SI: 1 inch = 25.4 mm, 1 foot = 304.8 mm.

**FIGURE R507.9.2(2)**  
**DECK ATTACHMENT FOR LATERAL LOADS**

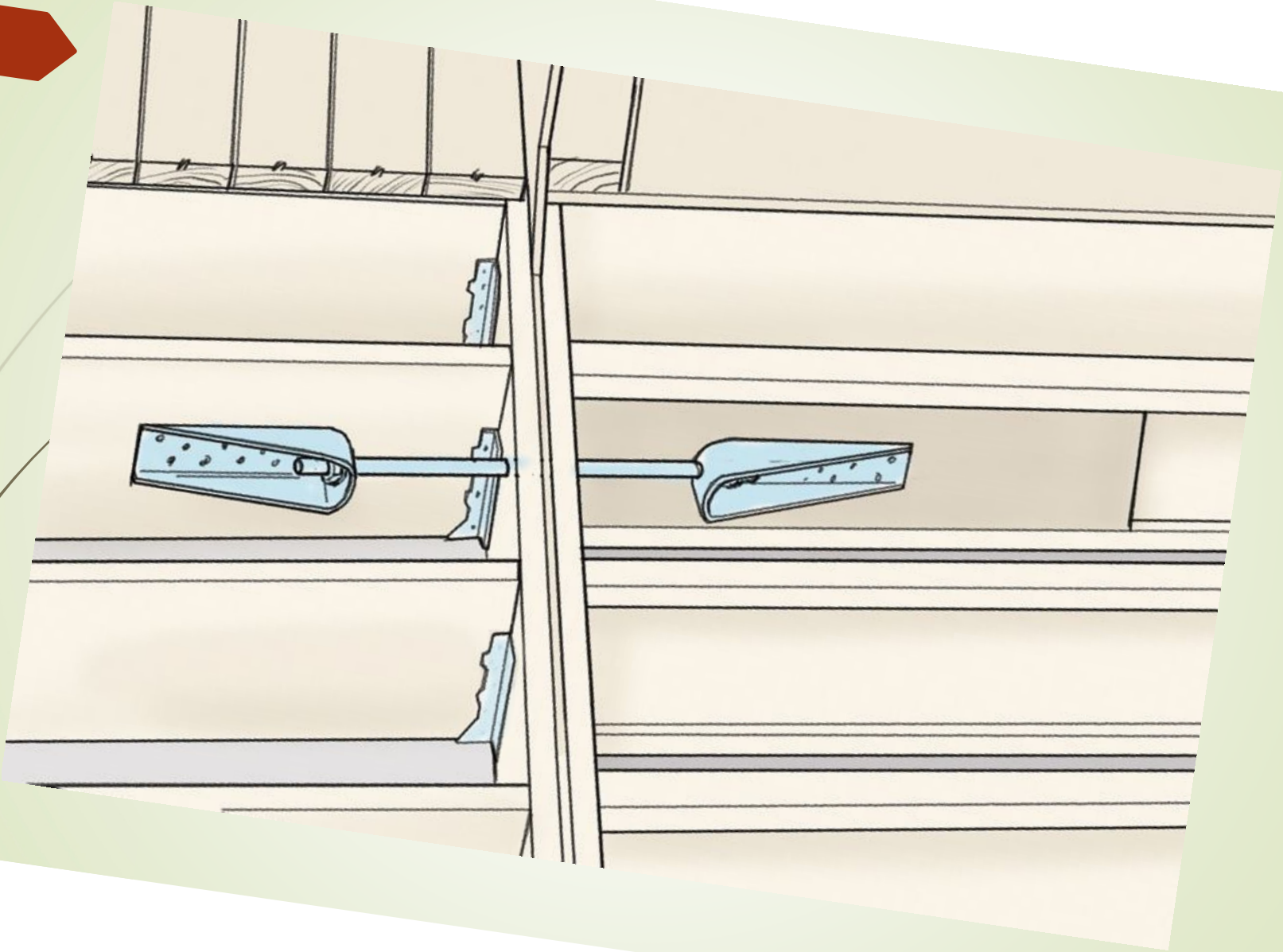

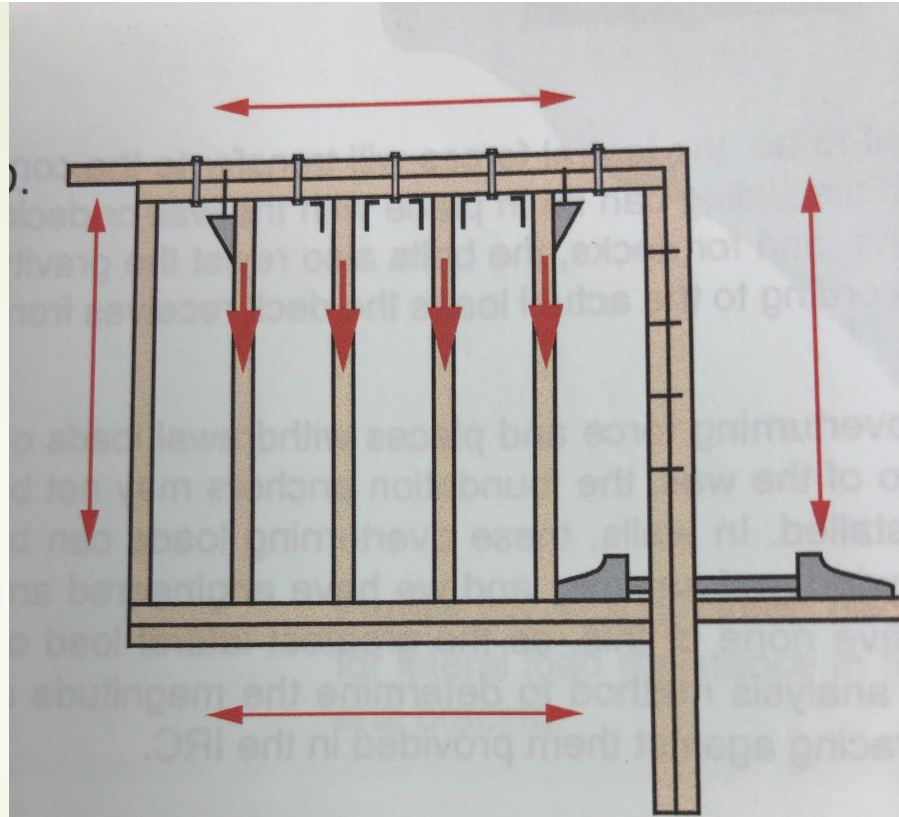

Figure 7-1-3



<https://www.youtube.com/watch?v=nVh7skLCfCk>